

DESCRIPTION

- Metal construction with chrome plated finish
- 1/2" IPS connections
- Includes showerhead, arm and flange

OPERATION

- Acrylic knob style handles with hot and cold color indicators
- Volume and temperature controlled by rotating either handle counterclockwise to open and clockwise to close

FLOW

- Showerhead is limited to 2.5 gpm (9.5 L/min) max.

CARTRIDGE

- 1224 cartridge design
- Nonmetallic and stainless steel materials

STANDARDS

- Designed and manufactured to comply with the requirements of: CSA B-125 and ASME A112.18.1M and all applicable requirements referenced therein

WARRANTY

- Lifetime limited warranty against leaks, drips and finish defects to the original consumer purchaser
- 5 year warranty if used in commercial installations

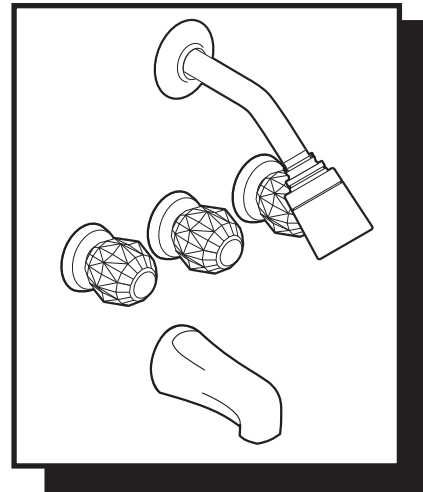

CHATEAU®
Three-Handle Tub/Shower Valve

Model: 2995

NOTE: See reverse side for illustrated parts

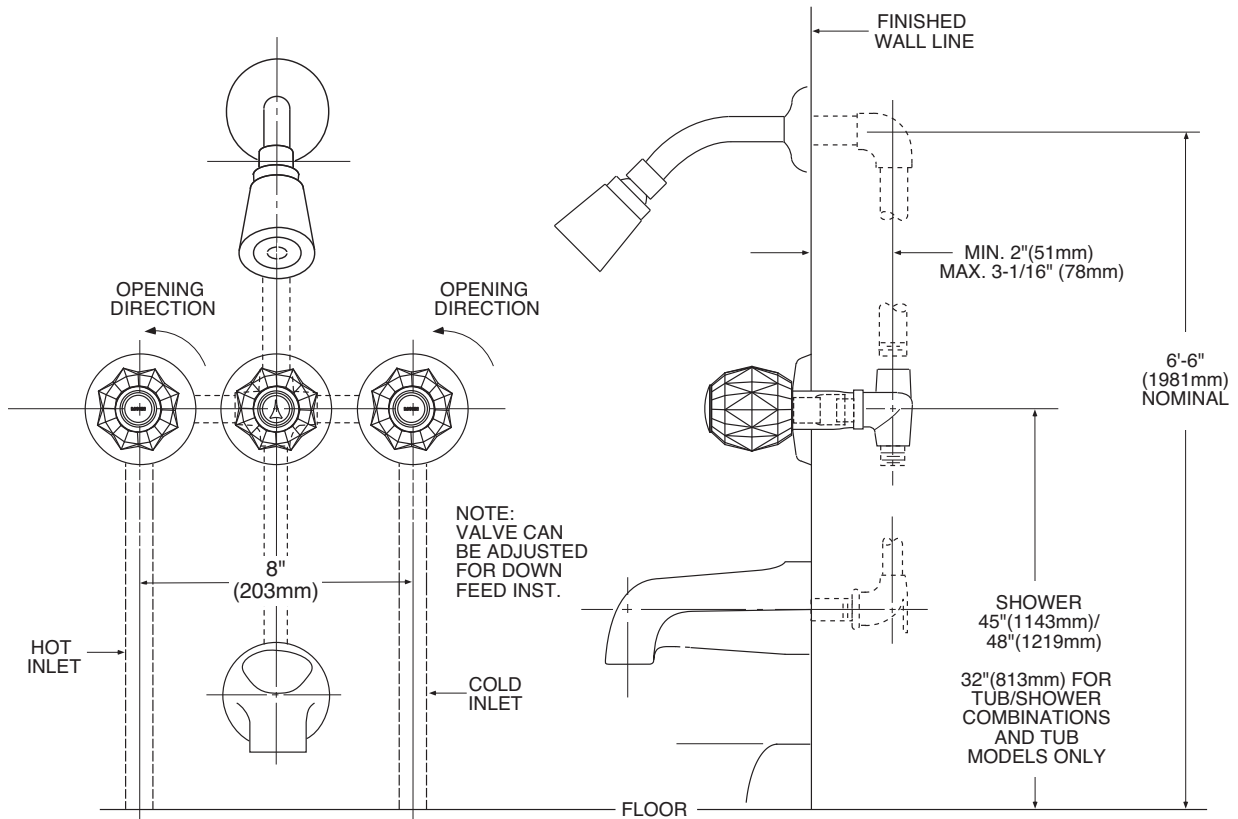

CRITICAL DIMENSIONS

(DO NOT SCALE)

DESCRIPTION

- Chrome plated metal construction
- 1/2" IPS connections
- Includes showerhead, arm and flange

OPERATION

- Dual control
- Acrylic knob style handles
- Volume and temperature controlled by rotating either handle counterclockwise to open and clockwise to close

FLOW

- Showerhead is limited to 2.5 gpm (9.5 L/min) max.

CARTRIDGE

- 1224 cartridge design
- Nonmetallic and stainless steel materials

STANDARDS

- Designed and manufactured to comply with the requirements of: CSA B-125 and ASME A112.18.1M and all applicable requirements referenced therein

WARRANTY

- Lifetime limited warranty against leaks, drips and finish defects to the original consumer purchaser
- 5 year warranty if used in commercial installations

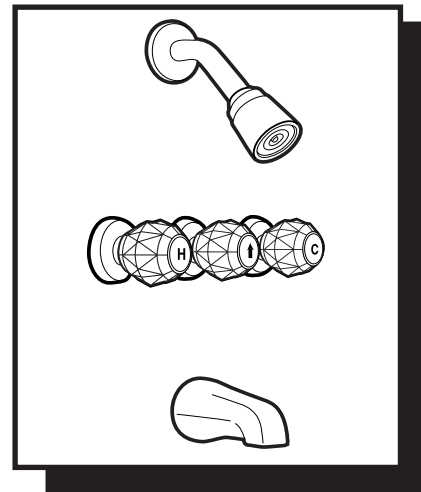

CHATEAU®
Three-Handle Tub/Shower Valve

Model: 2995

NOTE: See reverse side for illustrated parts

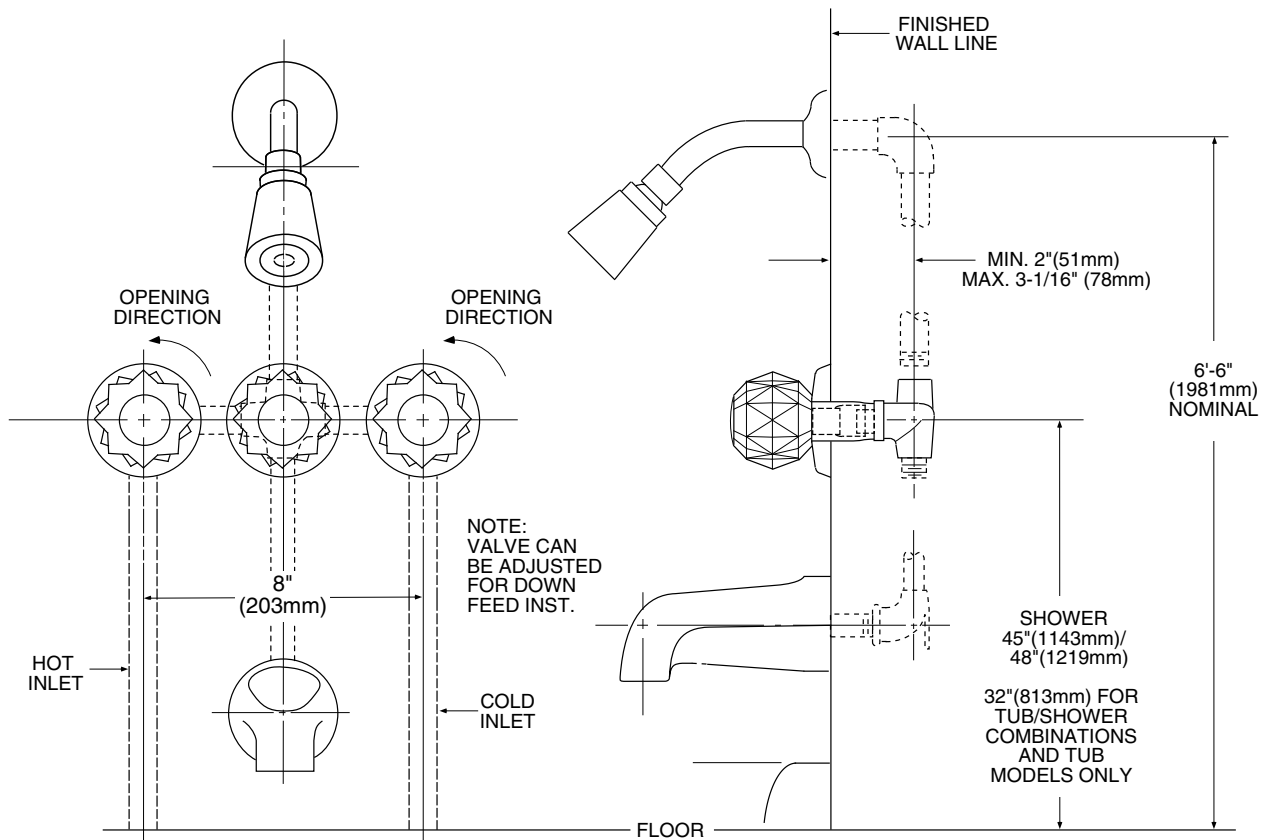

CRITICAL DIMENSIONS

(DO NOT SCALE)