

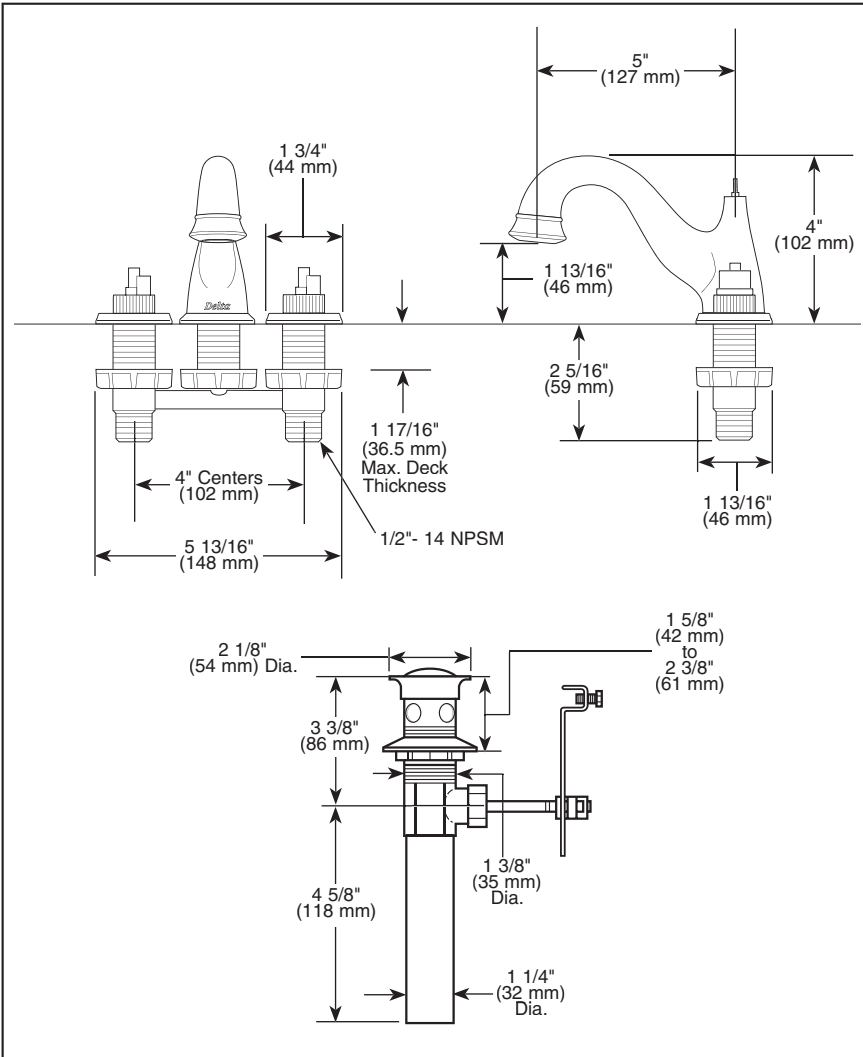

4540-LHP

Submitted Model No.: \_\_\_\_\_

Specific Features: \_\_\_\_\_



**Available LHP Handle Options**

▲ Designate proper finish suffix

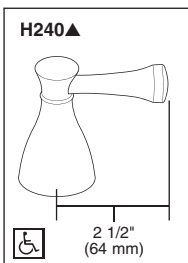

Delta reserves the right (1) to make changes in specifications and materials, and (2) to change or discontinue models, both without notice or obligation. Dimensions are for reference only. See current full-line price book for finish options and product availability.  
 DSP-L-4540-LHP Rev. A



**LAVATORY FAUCETS**

- Lockwood™ Bath Collection
- Two Handle Deck Mount
- 3 Hole Sink Applications
- 4" Mini-Widespread

**STANDARD SPECIFICATIONS:**

- Solid brass fabricated body.
- 4" (102 mm) mini-widespread.
- 5" (127 mm) long, 4" (102 mm) high rigid spout.
- LHP - Less Handle Program. See handle options below.
- 1/4 turn handle stops.
- Hot and cold stems are interchangeable.
- Control mechanism shall be of the rotating cylinder type with stainless steel plate and 180° rotation, with replaceable non-metallic seats operating in stainless steel lined sockets.
- 1/2"-14 NPSM threaded male inlet shanks.
- Models have metal drain with pop-up type fitting with plated flange and stopper.

**WARRANTY**

- Lifetime Faucet and Finish Limited Warranty to the original consumer purchaser to be free from defects in material and workmanship.
- 5 Year Limited Warranty for usage in all industrial, commercial and business applications.



**COMPLIES WITH:**

- ASME A112.18.1 / CSA B125.1
- ASME A112.18.2 / CSA B125.2
- Indicates ADA compliance to ICC/ANSI A117.1
- IAPMO Listed
- CSA Certified

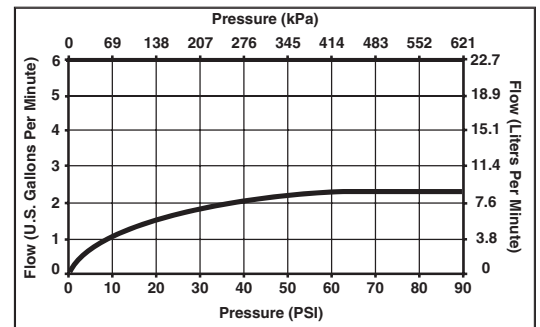

Indianapolis, Indiana 46280  
 A Division of Masco Corporation of Indiana  
 © 2006 Masco Corporation of Indiana